

THE USER INTERFACE

The user has a display and four keys for controlling status and programming of the instrument.

KEYS AND MENUS

UP key		Scrolls through the menu items Increases the values
DOWN key		Scrolls through the menu items Decreases the values
FNC key		ESC function (exit)
SET key		Accesses the setpoint Accesses the menus Confirms the commands

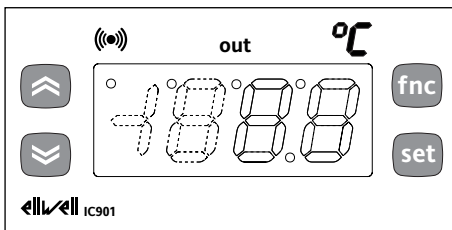

At start-up the instrument performs a Lamp Test; for few seconds the display and the leds blink, in order to verify their integrity and correct operation. The instrument has two main menus: the "Machine Status" and "Programming" menu.

ACCESSING AND USING MENUS

Resources are arranged in a menu, which can be accessed by pressing and quickly releasing the "set" key ("Machine Status" menu) or by holding down the "set" key for more than 5 seconds ("Programming" menu).

To access the contents of each folder, indicated by the relevant label, just press the "set" key once.

You can now scroll through the contents of each folder, modify it or use its functions.

If you do not use the keyboard for over 15 seconds (time-out) or if you press the "fnc" key once, the last value shown on the display is confirmed and you return to the previous screen mask.

MACHINE STATUS MENU

(See Machine Status Menu Diagram)

To access the "Machine Status" menu Press and quickly release the "set" key. If alarms are not present, the label "SEt" appears. By using the "UP" and "DOWN" keys you can scroll through the other folders in the menu:

- AL: alarm folder (if present);
- Pb1: probe 1 value folder;
- SEt: Setpoint setting folder.

Set Setting

Access the "Machine Status" menu by pressing and quickly releasing the "set" key. The label of the "SEt" folder appears. To display the Setpoint value press the "set" key again.

The value appears on the display.

To change the Setpoint value, use the "UP" and "DOWN" keys within 15 seconds.

If the parameter is LOC = y the Setpoint cannot be changed.

Alarm on

If alarm condition exists, when accessing The "Machine Status" menu the "AL" folder label appears (see the "Diagnostics" section).

Displaying Probes

By pressing the "set" key when the appropriate label appears, the value of the probe associated to it is displayed.

PROGRAMMING MENU

(See Programming Menu Diagram)

To enter the "Programming" menu, press the "set" key for more than 5 seconds. If specified, the access PASSWORD will be requested, (parameter "PA1"), and the label of the first folder will follow.

To scroll through the other folders, use the "UP" and "DOWN" keys; the folders contain the level 1 and 2 parameters. The level 2 parameters may be protected by a second password (parameter "PA2").

To enter the folder, press "set". The label of the first visible parameter appears. To scroll through the other parameters, use the "UP" and "DOWN" keys; to change the parameter, press and release "set", then set the desired value using the "UP" and "DOWN" keys, and confirm with the "set" key to move to the next parameter.

PLEASE NOTE: It is suggested to switch-off and switch-on again the instrument every-time it is changed the configuration of the parameters: this prevents malfunctioning on regulation and delay time occurring.

PASSWORD

The password "PA1" allow access to level 1 parameters. In the standard configuration passwords are not present.

To enable them and assign them the desired value, access the "Programming" menu, within the folder with the "diS" label.

If passwords are enabled, you will see PA1 at the entrance of the "Programming" menu;

COPY CARD

The Copy Card is an accessory connected to the TTL serial port which allows programming quickly the instrument parameters. The operation is performed as follows:

Fr-Format

This command allows copy card formatting, an operation recommended in case of first use.

Warning: if the copy card has been programmed, using the "Fr" the data entered are erased. This operation cannot be cancelled.

UL-Upload

This operation loads the programming parameters from the instrument.

dL-Download

This operation downloads to the instrument the programming parameters. The operations are performed accessing the folder identified by the "FPr" label and selecting, according to the case, "UL", "dL" or "Fr" commands; the operation is confirmed by pressing the "set" key. If the operation is successful an "y" is displayed, on the contrary, if it fails a "n" will be displayed.

NOTE:

- **UPLOAD: instrument --> Copy Card**
- **DOWNLOAD: Copy Card --> instrument.**

KEYBOARD LOCKING

The instrument includes a facility for disabling the keyboard, by programming the "Loc" parameter (see folder with "Dis" label). If the keyboard is locked, you can still access the programming menu by pressing the "set" key.

The Setpoint can also be viewed.

LED

Position	Associated function	Status
out	Relay 1	ON for relay ON, flashing for delay, disabled protection or activation
	Alarm	ON for an active alarm; blink if silenced

DIAGNOSTICS

The alarm condition is always signalled by the buzzer (if present) and by the led of the alarm icon (🔊)

The alarm signal produced by a faulty thermostat probe (probe 1) is shown as E1 on the instrument display.

Error table

DISPLAY	ERROR
E1	Thermostat probe fault

WARNING!: In 15A version buzzer is not available.

When the sensor detects an error condition:

- the code E1 is displayed
- the regulator is activated as indicated by the "On" and "Off" parameters if programmed for the duty cycle or:

Ont	Of	Regulator output
0	0	OFF
0	>0	OFF
>0	0	ON
>0	>0	dc

Other signalling alarm are not shown on the instrument display, but from the "Machine Status" menu within the "AL" folder.

MINIMUM AND MAXIMUM TEMPERATURE ALARMS

Regulation of the minimum and maximum temperature alarms refers to the thermostat probe.

The temperature limits defined by the "HAL" (maximum temperature alarm) and "LAL" parameters (minimum temperature alarm) are in absolute temperature value. When an alarm status occurs, if no alarm exclusion phases are underway (see alarm exclusion parameters), the alarm set icon is lit up and the buzzer, and/or the relay configured as an alarm, is activated. The occurrence of this alarm does not in any way effect the control activities in progress. This alarm status can be viewed in the "AL" folder with AH1-AL1 labels.

DISPLAY	ALARM
AH1	High temperature alarm (referred to the thermostat probe or probe 1)
AL1	Low temperature alarm (referred to the thermostat probe or probe 1)

To silence alarms press any key.
If silenced it will blink.
Alarms are considered as absolute values.

INSTALLATION

The instrument is designed for flush panel mounting. Insert the unit through a 71x29 mm panel cut-out and affix with the U-bracket supplied.

Select a location which will not be subject to high humidity or condensation and allow some ventilation to provide cooling to the instrument.

ELECTRICAL CONNECTIONS

Attention! Never work on electrical connections when the machine is switched on.

The instrument is equipped with screw terminal boards for connection of electrical cables with a diameter of 2.5 mm² (one conductor only per terminal for power connections). For the capacity of the terminals, see the label on the instrument. Relay outputs are voltage free. Do not exceed the maximum permissible current – in case of higher loads, use a contactor of adequate power. Make sure that the supplied voltage matches the values specified for the instrument.

In the versions supplied on 12V, the power supply must be provided via a safety transformer protected by a 250 mA delayed fuse. The probes do not have any insertion polarity and can be lengthened by using a normal bipolar cable (note that if the probes are lengthened, this will affect the behaviour of the instrument in terms of EMC electro-magnetic compatibility – wiring must be done with great care). We advise you to keep the probe and supply cables well away from the power cables.

CONDITIONS OF USE

PERMITTED USE

For safety reasons the instrument must be installed and used according to the instruction provided and in particular, under normal conditions, parts bearing dangerous voltage levels must not be accessible.

The device must be adequately protected from water and dust as per the application and must also only be accessible via the use of tools (with the exception of the frontlet).

The device is ideally suited for use on household appliances and/or similar refrigeration equipment and has been tested with regard to the aspects concerning European reference standards on safety. It is classified as follows:

- according to its manufacture: as an automatic electronic control device to be incorporated by independent mounting;
- according to its automatic operating features: as a 1 B-type operated control type;
- as a Class A device in relation to the category and structure of the software

UNPERMITTED USE

Any other use other than that permitted is de facto prohibited. It should be noted that the relay contacts provided are of a practical type and therefore subject to fault. Any protection devices required by product standards or dictated by common sense due to obvious safety reasons should be applied externally.

TECHNICAL DATA

Frontal panel protection: IP65.

Casing: plastic body in resin type PC+ABS UL94 V-0, inspection window in polycarbonate, buttons in thermoplastic resin.

Dimensions: frontal panel 74x32 mm, depth 60 mm.

Installation: on panel, with drilling template 71x29 mm (+0.2/-0.1 mm).

Use temperature: -5...55 °C.

Storage temperature: -30...85 °C.

Use environment humidity: 10...90 % RH (not condensing).

Storage environment humidity: 10...90% RH (not condensing).

Viewing range: -50...99 °C (NTC), -55...99 °C (PTC) on 3 digit 1/2 + mark display.

Analog inputs: one PTC or NTC input (selectable through parameter).

Serial: TTL for connection to Copy Card.

Digital outputs:

(A) one relay output, SPDT 8(3)A 250V~ relay,

(B) one relay output, SPST 8(3)A 250V~ relay or one relay output, SPST 15A (1hp) 250V~ relay (for relay capacities check on the instrument label)

Measuring range: from -55 to 99 °C.

Accuracy: 0.5% better than end scale + 1 digit.

Resolution: 1 °C.

Consumption

• model 230V: 3 VA max.

• model 12V: 1,5 VA max.

Power supply: 12 V~/± ±10% or 230V~ ±10% 50/60 Hz.

Warning: check the power supply specified on the instrument label; for relay and power supply capacities, contact the Sales Office).

PLEASE NOTE: The technical data included in this document, related to measurement (range, accuracy, resolution, etc.) refer to the instrument itself, and not to its equipment such as, for example, sensors. This means, for example, that sensor(s) error(s) shall be added to the instrument's one.

Tab. 1 Parameter table

PARAMETER	DESCRIPTION	RANGE	DEFAULT*	VALUE**	LEVEL***	U.M.
	REGULATOR (folder with "CP")					
dIF	Relay regulator tripping differential. The regulator stops on reaching the Setpoint value (as indicated by the adjustment probe), and restarts at temperature value equal to the Setpoint plus the value of the differential. Note: the value 0 cannot be assumed.	1...30	2		1	°C/°F
HSE	Maximum possible setpoint value.	LSE..99	99		1	°C/°F
LSE	Minimum possible setpoint value.	-55...HSE	-55		1	°C/°F
HC	Heat/Cool Mode. If set to H the generic regulator actuates for hot operation. If set to C the generic regulator actuates for cold operation	H/C	C		1	flag
	REGULATOR PROTECTIVE DEVICES (folder with "CP" label)					
Ont	Regulator activation time in the event of faulty probe. If set to "1" with Oft at "0", the regulator is always on, while for Oft >0, it functions always in duty cycle mode.	0...250	0		1	min
Oft	Regulator in disabled state time in the event of a faulty probe. If set to "1" with Ont at "0", the regulator is always off, while at Ont >0, it functions always in duty cycle mode.	0...250	1		1	min
dOn	Delay time in activating the regulator relay after switch-on of instrument.	0...250	0		1	sec
dOF	Delay after switch off. The indicated time must elapse between switch-off of the regulator relay and the successive switch-on.	0...250	0		1	min
dbi	Delay between switch-ons. The indicated time must elapse between two successive switch-ons of the regulator.	0...250	0		1	min
OdO (!)	delay time in activating the outputs after switch-on of the instrument or after a power failure.	0...250	0		1	min
	ALARMS (folder with "AL" label)					
AFd	Alarm Fan differential. Alarm differential.	1...50	2		1	°C/°F
HAL	Higher ALarm. Maximum temperature alarm. Temperature value (in absolute value), which if exceeded in an upward direction triggers the activation of the alarm signal.	LAL...150	50		1	°C/°F
LAL	Lower ALarm. Minimum temperature alarm. Temperature value (in absolute value), which if exceeded in a downward direction, triggers the activation of the alarm signal.	-50...HAL	-50		1	°C/°F
PAO	Power-on Alarm Override. Alarm exclusion time after instrument switch on, after a power failure.	0...10	0		1	hours
tAO	temperature Alarm Override. Temperature alarm signal delay time.	0...999	0		1	min
	DISPLAY (folder with label "diS")					
LOC	Keyboard locking (set and keys). However, you can enter parameter programming, modify them and change the status of this parameter to unlock the keyboard. y = yes; n = no.	n/y	n		1	flag
PA1	Password 1. When enabled (value other than 0) it constitutes the access key for level 1 parameters.	0...250	0		1	num.
CA1	Calibration 1. Positive or negative temperature value added to the value read on the adjustment room probe (probe 1) before being displayed and used for adjustment.	-12...12	0		1	°C/°F
dro	Selection of °C or °F to view the temperature read by the probe. 0 = °C, 1 = °F.	0/1	1		1	flag
	CONFIGURATION (folder with label "CnF")					
H00 (*) (!)	Probe type selection, PTC or NTC. 0 = PTC; 1 = NTC.	0/1	0/1*		1	flag
rEL	Device version. Read only parameter.	/	/		1	/
tAb	Reserved. Read only parameter.	/	/		1	/
	COPY CARD (folder with label "Fpr")					
UL	UpLoad: transferring parameters from instrument to Copy Card.	/	/		1	/
dL	downLoad: transferring parameters from Copy Card to instrument.	/	/		1	/
Fr	Format. Erasing all data in the copy card. PLEASE NOTE: using "Fr" parameter (copy card formatting) the data within the copy card will be lost permanently. The operation cannot be cancelled.	/	/		1	/

* DEFAULT column: for H00 parameter default is depending on model

* NOTE 1: Switch off and switch on again the instrument after changing the input type NTC/PTC (par. H00)

** VALUE column: to be filled manually, with customized settings (if different from the default value).

*** LEVEL column: indicates the level of visibility of parameters accessible by PASSWORD (see the related paragraph)

(!) WARNING!

• If one or more of these parameters highlighted with (!) are modified, the controller must be switched off and switched on again to ensure correct operation.

LIABILITY AND RESIDUAL RISKS

Eliwell & Controlli s.r.l. shall not be liable for any damages deriving from:

- installation/use other than that prescribed and, in particular, that which does not comply with safety standards anticipated by regulations and/or those given herein;
- use on boards which do not guarantee adequate protection against electric shock, water or dust under the conditions of assembly applied;
- use on boards which allow access to dangerous parts without the use of tools;
- tampering with and/or alteration of the products;

DISCLAIMER

This manual and its contents remain the sole property of Eliwell & Controlli s.r.l., and shall not be reproduced or distributed without authorization. Although great care has been exercised in the preparation of this document, Eliwell & Controlli s.r.l., its employees or its vendors, cannot accept any liability whatsoever connected with its use. Eliwell & Controlli s.r.l. reserves the right to make any changes or improvements without prior notice.

MENU DIAGRAMS

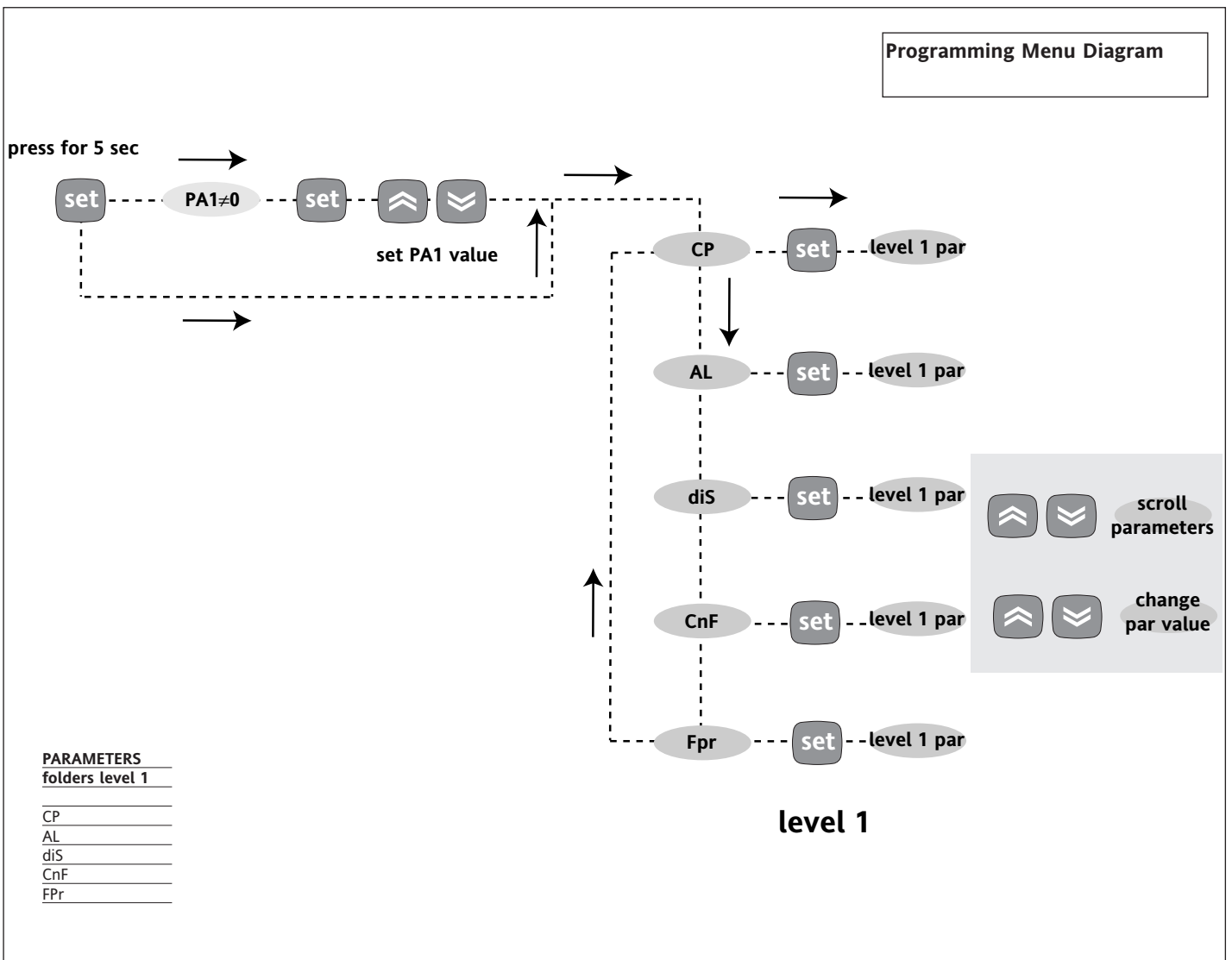
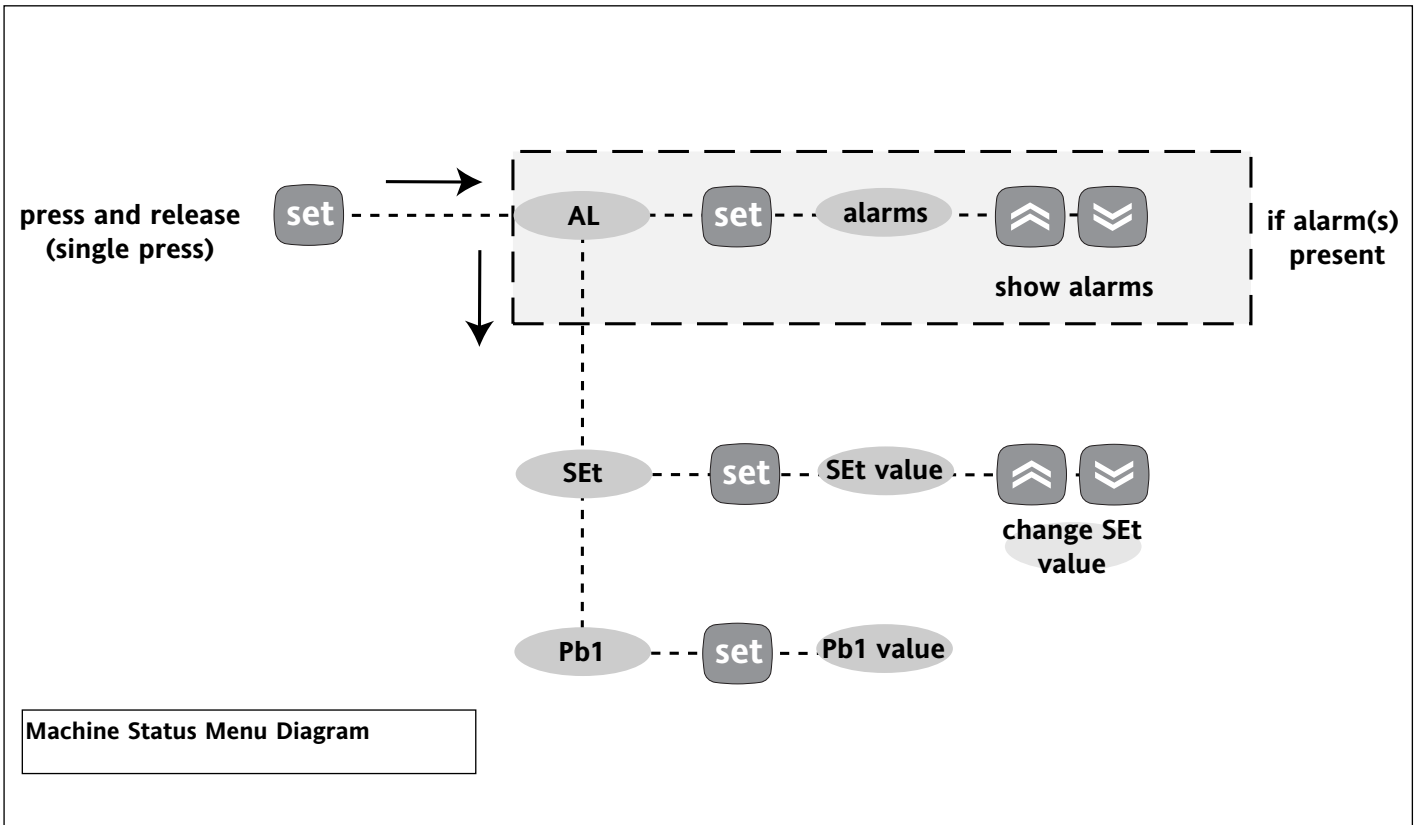

WIRING

1 - 2	N.O. regulator 1 relay output out1
1 - 3	N.C. regulator 1 relay output out1
4 - 5	N.O. regulator 2 relay output (alarm) out2
6 - 7	Power supply 1,5 VA max. (12V version) Power supply 3 VA max. (230V version)
8 - 10	Probe 1 input (thermostat)
A	TTL input for Copy Card

PLEASE NOTE:

- User Default Settings
- for relay capacities check on the instrument label

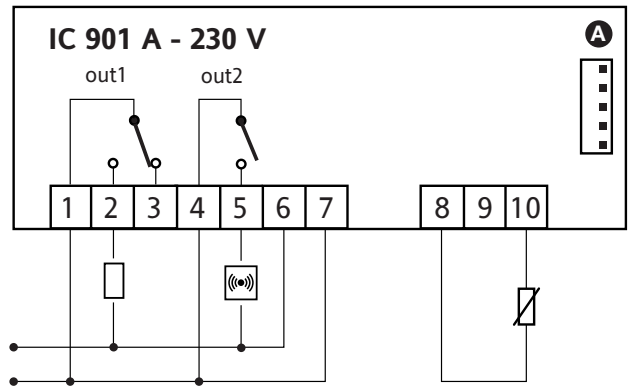
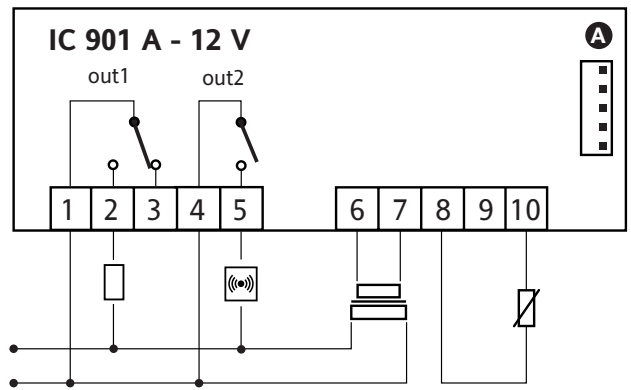

WIRING

1 - 2	N.O. regulator 1 relay output (alarm) out1
1 - 3	N.C. regulator 1 relay output (alarm) out1
4 - 5	N.O. regulator 2 relay output out2
6 - 7	Power supply 1,5 VA max. (12V version) Power supply 3 VA max. (230V version)
8 - 10	Probe 1 input (thermostat)
A	TTL input for Copy Card

PLEASE NOTE:

- User Default Settings
- for relay capacities check on the instrument label

WARNING:

For 15A version buzzer is not available

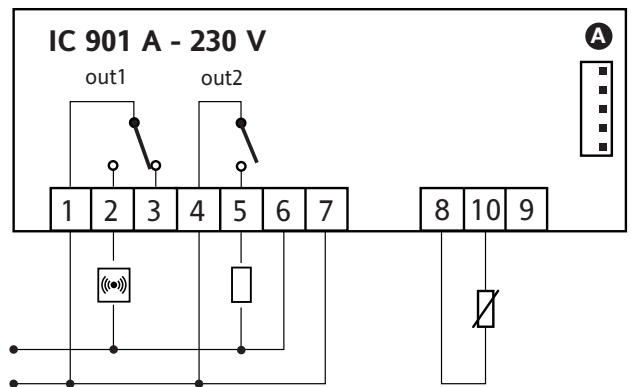
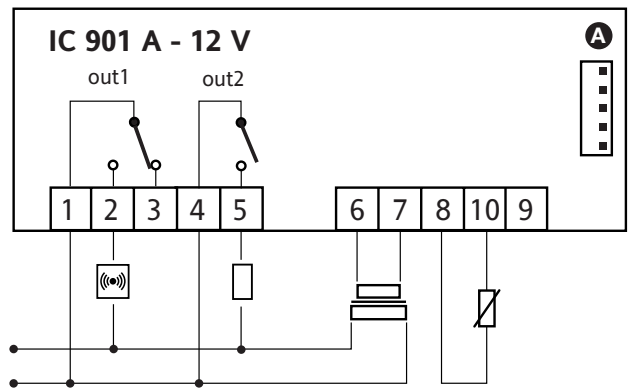

Eliwell & Controlli s.r.l.

Via dell'Industria, 15 Zona Industriale Paludi
32010 Pieve d'Alpago (BL) ITALY
Telephone +39 0437 986111
Facsimile +39 0437 989066
Internet <http://www.eliwell.it>

Technical Customer Support:

Email: techsuppeliwell@invensys.com
Telephone +39 0437 986300

**Climate Controls Europe
An Invensys Company**

6/2004 eng
cod. 9IS42084

